

National Crane Series NBT15

Product Guide

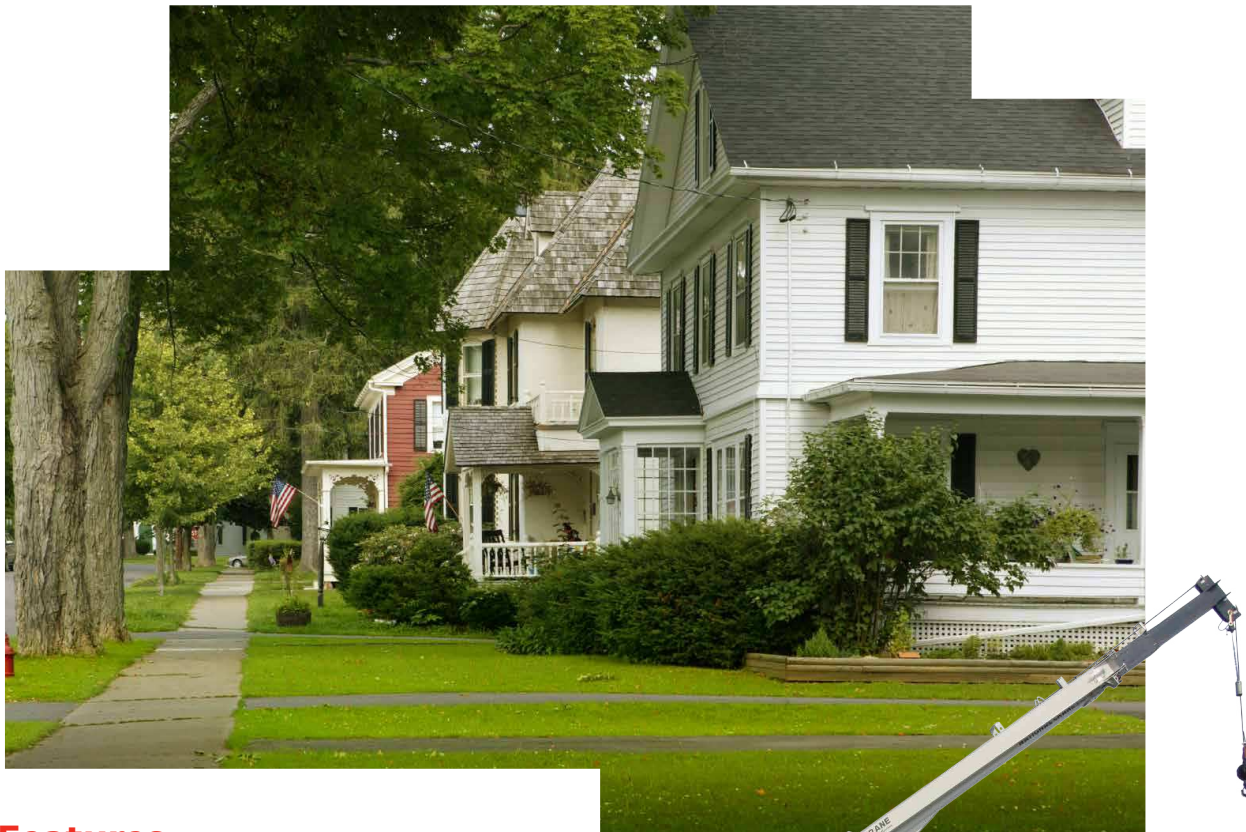

Features

- 13,4 t (15 USt) rating
- 18,3 m (60 ft) three-section boom
- Self-lubricating Easy Glide wear pads
- Internal anti-two block
- Load sense hydraulics
- Radio remote control



Features

National Crane Series NBT15

- 13,4 t (15 USt) maximum capacity
- 21,0 m (69 ft) maximum tip height (main boom)
- 27,7 m (91 ft) maximum tip height (boom with jib)

Three-section boom

At 18,3 m (60 ft), the NBT15 three-section boom is the longest in its size range. The long boom allows the operator to perform more lifts without the use of a jib, reducing setup time and improving efficiency. Also available is a 6,7 m (22 ft) single-section jib. LMI option is required for jib.



Radio remote control

The NBT15 comes standard with radio remote control. The controller can be docked at either of the dual side operator platforms or undocked for wireless operation.

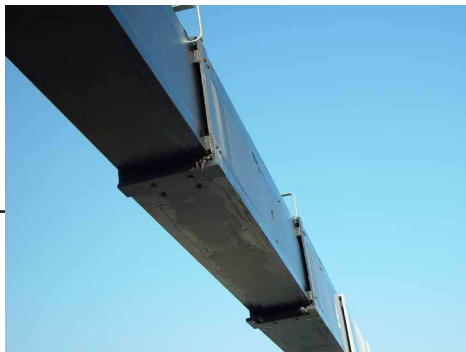

Easy Glide boom wear pads

Easy Glide boom wear pads reduce the conditions that cause boom chatter and vibration. The net result is smoother crane operation.



Outriggers

The NBT15 comes equipped with out and down outriggers and ASH rear stabilizers. The outriggers can be positioned at full-span, mid-span and fully retracted. An optional single front outrigger is also available.



*Product may be shown with optional equipment.

National Crane is proud to introduce the Series NBT15

- The steel torsion box and flatbed further reduce frame flex
- Speedy-reeve boom tip and sheave blocks simplify rigging changes by decreasing the time needed to change line reeving
- Crane components painted before assembly reduce the possibility of rust, improves serviceability and enhances the appearance of the machine
- The Series NBT15 is standard with 410° non-continuous rotation
- Bearings on the boom retract cables can be greased through access holes in the boom side plates
- Anti two-block reel is routed internally as standard, but can be re-routed externally
- The boom sheave case is open, allowing access to replace the internal anti-two-block wire and to observe internal boom components
- Internal boom parts have been reduced, decreasing service time when re-building the machine
- Engine start/stop switches, emergency stop, and throttle controls located on remote control
- Outriggers are equipped with a motion alarm and an outrigger monitoring system
- Hydraulic reservoir capacity of 25 gal

Contents

Specifications	5
Mounting configuration	7
Dimensions	8
Working range	9
Load charts	10
Accessories	13

Specifications

Boom and jib combinations data

NBT15 - 60: Equipped with a 7,4 m - 18,3 m (24 ft - 60 ft) three-section boom. This model can be equipped with a 6,7 m (22 ft) single-section jib. Maximum tip height with 6,7 m (22 ft) jib is 27,7 m (91 ft)

7,4 m - 18,3 m (24 ft - 60 ft) three-section hydraulic boom

15FJ22 6,71 m (22 ft) single-section jib



Specifications

NBT15 winch data

- All winch pulls and speeds are shown on the third layer.
- Winch line pulls would increase on the first, second, and third layers.
- Winch line speed would decrease on the first, second layers.
- Winch line pulls may be limited by the winch capacity or the ANSI 5 to 1 cable safety factor.

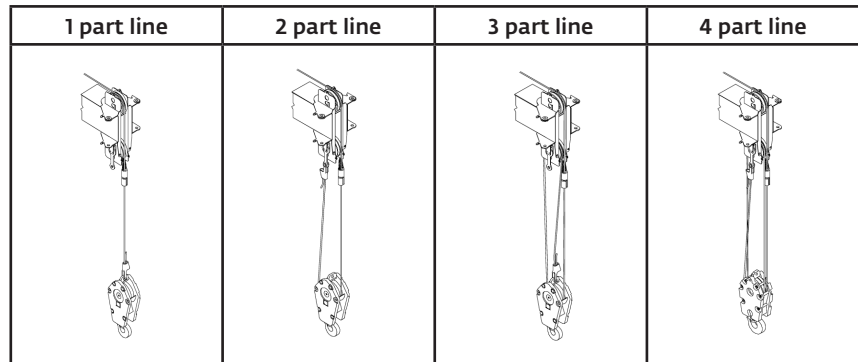

Standard planetary winch	Cable supplied	Average breaking strength	Max. pull	Max. pull	Max. pull	Max. pull
Low speed	9/16" 18x19 Class Rotation Resistant EIPS, WSC	17 463 kg (38,500 lb)	3500 kg (7700 lb) 37 m/min (120 fpm)	7000 kg (15,400 lb) 18 m/min (60 fpm)	10 500 kg (23,100 lb) 12 m/min (40 fpm)	13 630 kg (30,000 lb) 9 m/min (30 fpm)
High speed	9/16" 18x19 Class Rotation Resistant EIPS, WSC	17 463 kg (38,500 lb)	1361 kg (3000 lb) 55 m/min (180 fpm)	2722 kg (6000 lb) 27 m/min (90 fpm)	4082 kg (9000 lb) 18 m/min (60 fpm)	5443 kg (12,000 lb) 14 m/min (45 fpm)

Winch	Fourth layer pull	Allowable cable pull
Standard planetary	1361 kg (3000 lb) high speed 3493 kg (7700 lb) low speed	3493 kg (7700 lb) 3493 kg (7700 lb)

Block type	Rating	Weight
Downhaul weight	4,46 t (5 USt)	68 kg (150 lb)
1-sheave block	13,39 t (15 USt)	129 kg (285 lb)
2-sheave block	20,2 t (22 USt)	161 kg (355 lb)

Mounting configuration

The configurations are based on the NBT15 with an 85% stability factor. The complete unit must be installed in accordance with factory requirements and a test performed to determine actual stability and counterweight requirements since individual truck chassis vary.

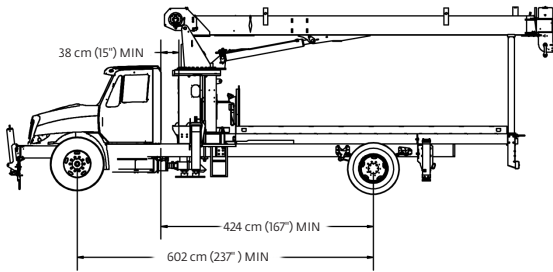

Configuration 1: 360° Full Capacity Work area (extended front frame rails required for SFO installation)

Working area	360°
Gross Axle Weight Rating Front	5443 kg (12,000 lb)
Gross Axle Weight Rating Rear	9525 kg (21,000 lb)
Gross Vehicle Weight Rating	14 969 kg (33,000 lb)
Wheelbase	602 cm (237 in) minimum
Cab to Axle/trunnion (CA/CT)	429 cm (169 in) minimum
Frame Section Modulus (SM) under crane with 758 MPa (110,000 PSI)	261 cm ³ (15.9 in ³)
Frame Section Modulus (SM) over rear stabilizers with 758 MPa (110,000 PSI)	213 cm ³ (13 in ³)
Stability Weight, Front	3084 kg (6800 lb) minimum*
Stability Weight, Rear	1814 kg (4000 lb) minimum*
Estimated Average Final Weight	11 793 kg (26,000 lb)**

Requires front stabilizer for full capacity 360° around the truck. Requires front and rear stabilizers and standard subbase. Front stabilizer for this configuration requires 13.5 inch³ (50,000 PSI), or 6.2 inch³ (110,000 PSI) section modulus from back of the front spring hangers through front suspension and to the front stabilizer. Normally a tapered front frame cannot be reinforced to these minimums.

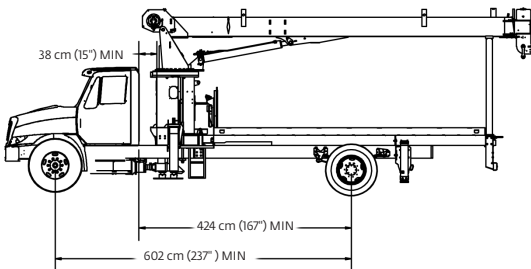

Configuration 2: 180° Full Capacity Work Area

Working area	180°
Gross Axle Weight Rating Front	5443 kg (12,000 lb)
Gross Axle Weight Rating Rear	9525 kg (21,000 lb)
Gross Vehicle Weight Rating	14 969 kg (33,000 lb)
Wheelbase	602 cm (237 in) minimum
Cab to Axle/trunnion (CA/CT)	429 cm (169 in) minimum
Frame Section Modulus (SM) under crane with 758 MPa (110,000 PSI)	261 cm ³ (15.9 in ³)
Frame Section Modulus (SM) over rear stabilizers with 758 MPa (110,000 PSI)	213 cm ³ (13 in ³)
Stability Weight, Front	3266 kg (7200 lb) minimum*
Stability Weight, Rear	1814 kg (4000 lb) minimum*
Estimated Average Final Weight	11 793 kg (26,000 lb)**

Allows the installation of NBT15 on a chassis with small frame by using standard subbase. In most cases, chassis will not require reinforcing and counterweight will not be required. This configuration gives a payload of app. 909 kg (2000 lb) on minimum truck. Requires standard subbase and rear stabilizers. Full capacity work area in rear 180° of vehicle from outrigger to outrigger.

Notes:

- Gross Vehicle Weight rating (GVWR) is dependent on all components of the vehicle (axles, tires, springs, frame, etc.) meeting manufacturers' recommendations; always specify GVWR when purchasing trucks
- Diesel engines require a variable speed governor and energize-to-run fuel solenoid for smooth crane operation; electronic fuel injection requires EET engine remote throttle

- All mounting data is based on a National Crane NBT15 with an 85% factor
- The complete unit must be installed in accordance with factory requirements, and a test performed to determine actual stability and counterweight requirements per SAE J765; contact the factory for details
- Transmission neutral safety interlock switch is required

Dimensions

NOTES:

MAX RATED LOAD MOMENT: 2,906,856 IN-LB
 THRUST AT MAX RATED LOAD MOMENT: 13,493 LB
 MAXIMUM THRUST: 35,593 LB
 LOAD MOMENT AT MAXIMUM THRUST: 2,042,444 IN-LB

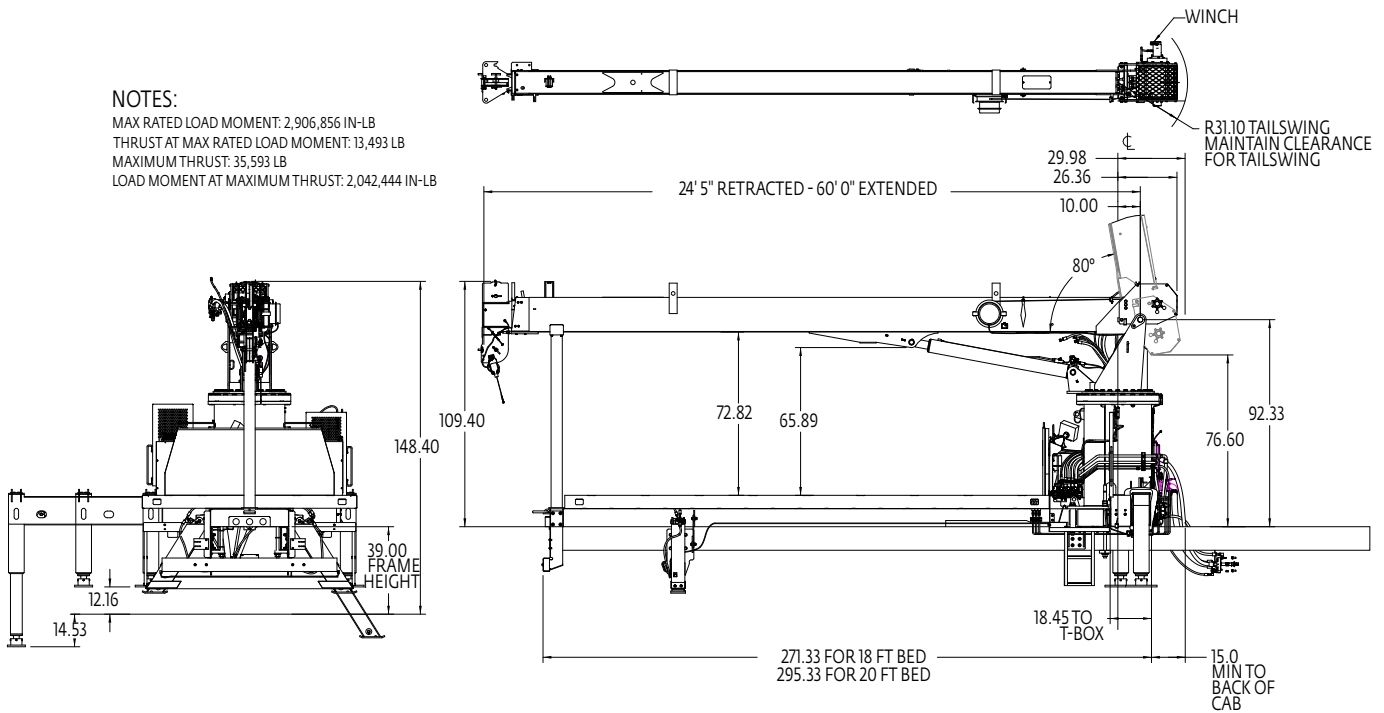

Series	G	Weight with oil
NBT1560	1,83 m (72 in)	6895 kg (15,200 lb)

Dimensions are in inches unless otherwise specified.

No jib.

Working range

10,3 m (60 ft) main boom, full-span outrigger, with 6,71 m (22 ft jib)

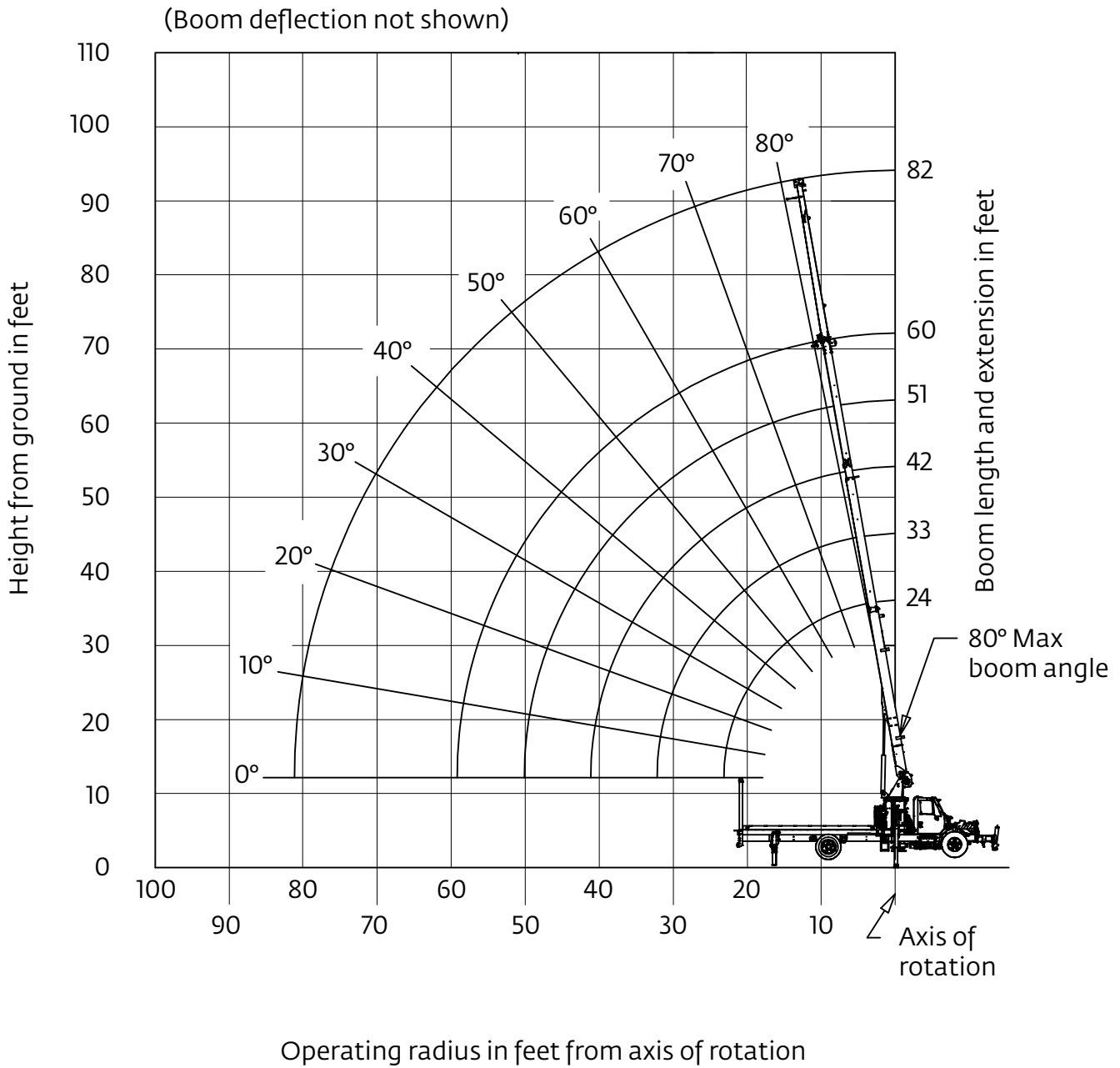

Load chart

10,3 m (60 ft) main boom, full-span outrigger, 360°, without stowed jib

Radius in feet	#01				
	Main boom length in feet				
	24	33-A	42-B	51-C	60
5	30,000 (79.9)				
8	22,500 (72.5)	19,700 (77.7)			
10	18,700 (67.2)	17,600 (73.9)	14,000 (78.1)		
12	16,200 (61.8)	15,300 (70.0)	13,000 (75.3)	9000 (78.2)	
14	14,200 (55.9)	13,450 (66.1)	11,500 (72.1)	8500 (76.0)	
16	12,600 (49.5)	12,000 (62.1)	9800 (69.1)	8000 (73.7)	4700 (76.7)
20	9800 (35.7)	9850 (53.5)	8100 (62.9)	6800 (69.4)	4500 (73.3)
25		7550 (42.0)	6800 (55.4)	6000 (63.1)	4200 (68.3)
30		5550 (24.3)	5700 (46.0)	5100 (56.3)	3950 (62.8)
35			4400 (34.6)	4500 (48.8)	3750 (57.2)
40			3500 (16.6)	3600 (40.1)	3400 (51.0)
45				2900 (29.1)	2900 (44.0)
50					2400 (35.8)
55					2050 (25.0)
Minimum boom angle (°) for indicated length (no load)					0
Maximum boom length (ft) at 0° boom angle (no load)					60

NOTE: () Boom angles are in degrees.

#LMI operating code. Refer to LMI manual for operating instructions.

Lifting capacities at zero degree boom angle					
Boom angle	Main boom length in feet				
	24	33-A	42-B	51-C	60
0°	5000 (23.7)	3500 (32.2)	2800 (41.2)	2150 (50.2)	1050 (59.2)

NOTE: () Reference radii in feet.

80043424

Load chart

10,3 m (60 ft) main boom, full-span outrigger, 360°, with 6,71 m (22 ft) jib

Radius in feet	#02				
	Main boom length in feet				
	24	33-A	42-B	51-C	60
5	29,650 (79.9)				
8	22,150 (72.5)	19,400 (77.7)			
10	18,350 (67.2)	17,300 (73.9)	13,750 (78.1)		
12	15,850 (61.8)	15,000 (70.0)	12,750 (75.3)	8800 (78.2)	
14	13,850 (55.9)	13,150 (66.1)	11,250 (72.1)	8300 (76.0)	
16	12,250 (49.5)	11,700 (62.1)	9550 (69.1)	7800 (73.7)	4550 (76.7)
20	9450 (35.7)	9550 (53.5)	7850 (62.9)	6600 (69.4)	4350 (73.3)
25		7250 (42.0)	6550 (55.4)	5800 (63.1)	4050 (68.3)
30		5250 (24.3)	5450 (46.0)	4900 (56.3)	3800 (62.8)
35			4150 (34.6)	4300 (48.8)	3600 (57.2)
40			3250 (16.6)	3400 (40.1)	3250 (51.0)
45				2700 (29.1)	2750 (44.0)
50					2250 (35.8)
55					1900 (25.0)
Minimum boom angle (°) for indicated length (no load)					0
Maximum boom length (ft) at 0° boom angle (no load)					60

NOTE: () Boom angles are in degrees.
#LMI operating code. Refer to LMI manual for operating instructions.

Lifting capacities at zero degree boom angle					
Boom angle	Main boom length in feet				
	24	33-A	42-B	51-C	60
0°	4650 (23.7)	3200 (32.2)	2550 (41.2)	1950 (50.2)	900 (59.2)

NOTE: () Reference radii in feet.

80043425

Load chart

10,3 m (60 ft) main boom, full-span outrigger, 360°, with 6,71 m (22 ft) jib

Radius in feet	#03
14.8	2000 (80.0)
21.5	1900 (75.0)
28.6	1550 (70.0)
35.3	1250 (65.0)
41.9	1100 (60.0)
48.1	950 (55.0)
53.9	850 (50.0)
58.9	800 (45.0)
64	700 (40.0)
67.8	650 (35.0)
71.5	600 (30.0)
Min. boom angle for indicated length (no load)	30°
Max. boom length at 0° boom angle (no load)	33 ft

80043251

NOTE: () Boom angles are in degrees.
#LMI operating code. Refer to LMI manual for operating instructions.

Boom extension capacity notes:

1. All capacities above the bold line are based on structural strength of boom extension.
2. Extension may be used for single line lifting service.
3. Radii listed are for a fully extended boom with the boom extension erected. For main boom lengths less than fully extended, the rated loads are determined by boom angle. For boom angles not shown, use the rating of the next lower angle.
Warning: Operation of this machine with heavier loads than the capacities listed is strictly prohibited. Machine tipping with boom extension occurs rapidly and without advance warning.
4. Boom angle is the angle above or below horizontal of the longitudinal axis of the boom base section after lifting rated load.
5. Capacities listed are with outriggers properly extended and vertical jacks set.
6. Do not lift over the main boom nose when jib is pinned on the boom tip.

Accessories

Heavy-duty Personnel Basket –

Strong but lightweight steel basket, gravity hung with swing lock and full body harness.

- B1-S
- BSA-1
- BSA-R1
- BSAY-2

Hydraulic Oil Cooler –

Hydraulic self-contained radiator system with electric fans cools oil under continuous operation.

- OC

Single Front Outrigger –

Center mount front stabilizer for 360° stability with 25 in vertical stroke.

- SFO

Bulkhead Options –

Steel 30 in solid wall bulkhead.

- BHSD

Spanish-Language Danger Decals, Control Knobs and Operator's Manuals –

- SDD
- SOM

Notes

Manitowoc Cranes

Regional headquarters

Americas

Manitowoc, Wisconsin, USA
Tel: +1 920 684 6621
Fax: +1 920 683 6277

Shady Grove, Pennsylvania, USA
Tel: +1 717 597 8121
Fax: +1 717 597 4062

Europe, Middle East, Africa

Ecully, France
Tel: +33 (0)4 72 18 20 20
Fax: +33 (0)4 72 18 20 00

China

Shanghai, China
Tel: +86 21 6457 0066
Fax: +86 21 6457 4955

Greater Asia-Pacific

Singapore
Tel: +65 6264 1188
Fax: +65 6862 4040

Regional offices

Americas

Brazil
Alphaville
Mexico
Monterrey
Chile
Santiago

Europe, Middle East, Africa

Czech Republic
Netvorice
France
Baudemont
Cergy
Decines
Germany
Langenfeld
Hungary
Budapest
Italy
Lainate
Netherlands
Breda
Poland
Warsaw
Portugal
Baltar
Russia
Moscow
South Africa
Johannesburg
U.A.E.
Dubai
U.K.
Buckingham

China

Beijing
Chengdu
Guangzhou
Xian

Greater Asia-Pacific

Australia
Brisbane
Melbourne
Sydney
India
Chennai
Delhi
Hyderabad
Pune
Korea
Seoul
Philippines
Makati City
Singapore

Factories

Brazil
Passo Fundo
China
TaiAn
Zhangjiagang
France
Charlieu
Moulins
Germany
Wilhelmshaven
India
Pune
Italy
Niella Tanaro
Portugal
Baltar
Fânzeres
Slovakia
Saris
USA
Manitowoc
Port Washington
Shady Grove

This document is non-contractual. Constant improvement and engineering progress make it necessary that we reserve the right to make specification, equipment, and price changes without notice. Illustrations shown may include optional equipment and accessories and may not include all standard equipment.